

12 素材 ①

(ページ)	(中分類)	(小分類)	(総合カタログ)
1	鋼材	ザム(ZAM)鋼板	12-1
2	ステンレス材	ステンレス平板 ①	12-2
3		ステンレス平板 ②	12-3
4		ステンレス デザイン エッチング板 ①	12-4
5		ステンレス デザイン エッチング板 ②	12-5
6		ステンレス フラットバー ①	12-6
7		ステンレス フラットバー ②	12-7
8		ステンレス フラットバー ③	12-8
9		ステンレス フラットバー ④	12-9
10		ステンレス 丸棒 ①	12-10
11		ステンレス 丸棒 ②	12-11
12		ステンレス アングル ①	12-12
13		ステンレス アングル ②	12-13
14		ステンレス 化粧パイプ	12-14
15		ステンレス 角パイプ	12-15
16		ステンレス チャンネル	12-16

ザム(ZAM)鋼板

※「ZAM」は日新製鋼が開発した(溶融亜鉛・アルミニウム・マグネシウム)合金めっき鋼板の商品名です。
 ※「ZAM」は日新製鋼の登録商標です。

ZAM

(亜鉛-アルミニウム6%-マグネシウム3%)の合金めっき層を持つ「溶融めっき鋼板」です。

- アルミニウムとマグネシウムの効果により、優れた耐食性、耐疵付き性、加工性を実現しています。
- (ペンタイトB・溶融亜鉛めっき鋼板)に比べて10~20倍、(ガルタイト・亜鉛-5%アルミニウムメッキ鋼板)に比べて5~8倍の優れた耐食性を有しています。
- 切断端面においても、めっき層から溶け出したアルミニウム・マグネシウムを含む緻密な亜鉛系保護被膜が端面部を覆うことにより、優れた耐食性を発揮します。
- 無機系クロムフリー処理(ZC)により、表面が無機系皮膜となる為、電気抵抗が低く、表面の導電性に優れています。
 そのため表面のスポット溶接性に高い能力を発揮します。
- 全くクロムを含まない皮膜ですので、環境不可物質に対応しており、環境に優しい材料です。

※トラックボデー部品、部材の材料に適した鋼板といえます。

コードNO	品名・サイズ			規格	めっき付着量	1枚重量kg	
0012706	ZAM鋼板	厚1.6t	1219×2438	クロムフリー	MSM-HC	90/90 g/m ²	37.9
00127073	ZAM鋼板	厚2.3t	1219×2438	クロムフリー	MSM-HK400	90/90 g/m ²	54.2
00127083	ZAM鋼板	厚3.2t	1219×2438	クロムフリー		90/90 g/m ²	75.2
00127093	ZAM鋼板	厚4.5t	1219×2438	クロムフリー		90/90 g/m ²	106
1109150	ZAM鋼板	厚6.0t	1219×2500	クロムフリー		90/90 g/m ²	144

※適用強度
 MSM-HC・・・一般用270N級
 MSM-HK400・・・構造用400N級

◆塩水噴霧試験結果(SST:JIS Z 2371)

※平坦部の耐食性比較

時間経過	500時間	1200時間	2500時間
ZAM			
溶融 55%アルミ 亜鉛 合金メッキ			
溶融亜鉛 5%アルミ 合金メッキ			
溶融亜鉛 メッキ			

※切断端面部の耐食性比較

時間経過	100時間	1000時間	5000時間
ZAM			
溶融 55%アルミ 亜鉛 合金メッキ			
溶融亜鉛 5%アルミ 合金メッキ			
溶融亜鉛 メッキ			

※試験体(メッキ付着量: 90/90 g/m² 無処理)

※試験体(板厚3.2t メッキ付着量: 120/120 g/m² 無処理)

荷台用部品

荷台用補助部品

フエンダー・工具箱
タンク・タイヤ・リガー

バンウィング部材
(アルミ・ポリ材料含む)

バンウィング部材

荷役部品

ランプ・電装部品

保安部品

補修部品

ダンプ部品

導風板

素材

ステンレス平板①

SUS304

■片面#400研磨

コードNO	商品名	材 質	板厚	幅	長さ	表面処理/ビニール	1枚重量kg
4350617	ステンレス平板	SUS304	0.6	× 1000	× 2000	#400研磨/SG	9.52
4350811	〃	〃	0.8	× 1000	× 2000	〃	12.7
4351014	〃	〃	1.0	× 1000	× 2000	〃	15.9
4351218	〃	〃	1.2	× 1000	× 2000	〃	19.0
4351519	〃	〃	1.5	× 1000	× 2000	〃	23.8
4352013	〃	〃	2.0	× 1000	× 2000	〃	31.7
4350646	ステンレス平板	SUS304	0.6	× 1219	× 2438	#400研磨/SG	14.1
4350840	〃	〃	0.8	× 1219	× 2438	〃	18.9
4351043	〃	〃	1.0	× 1219	× 2438	〃	23.6
4351247	〃	〃	1.2	× 1219	× 2438	〃	28.3
4351548	〃	〃	1.5	× 1219	× 2438	〃	35.4
4352042	〃	〃	2.0	× 1219	× 2438	〃	47.1

■片面ウロコ研磨

コードNO	商品名	材 質	板厚	幅	長さ	表面処理/ビニール	1枚重量kg
4330611	ステンレス平板	SUS304	0.6	× 1000	× 2000	ウロコ研磨/SPV白	9.52
4330815	〃	〃	0.8	× 1000	× 2000	〃	12.7
4331018	〃	〃	1.0	× 1000	× 2000	〃	15.9
4331019	〃	〃	1.2	× 1000	× 2000	〃	19.0
4331513	〃	〃	1.5	× 1000	× 2000	〃	23.8
4332017	〃	〃	2.0	× 1000	× 2000	〃	31.7
4330640	ステンレス平板	SUS304	0.6	× 1219	× 2438	ウロコ研磨/SPV白	14.1
4330844	〃	〃	0.8	× 1219	× 2438	〃	18.9
4331047	〃	〃	1.0	× 1219	× 2438	〃	23.6
4331241	〃	〃	1.2	× 1219	× 2438	〃	28.3
4331542	〃	〃	1.5	× 1219	× 2438	〃	35.4
4332046	〃	〃	2.0	× 1219	× 2438	〃	47.1

■片面#800研磨

コードNO	商品名	材 質	板厚	幅	長さ	表面処理/ビニール	1枚重量kg
4311494	ステンレス平板	SUS304	0.6	× 1219	× 2438	#800研磨/SPV白	14.1
4311504	〃	〃	0.8	× 1219	× 2438	〃	18.9
4311517	〃	〃	1.0	× 1219	× 2438	〃	23.6
4311520	〃	〃	1.2	× 1219	× 2438	〃	28.3
4311533	〃	〃	1.5	× 1219	× 2438	〃	35.4
4311546	〃	〃	2.0	× 1219	× 2438	〃	47.1

※商品の在庫・納期はご確認ください。

※上記以外のサイズも取り寄せ可能ですのでお問い合わせください。

荷台用部品

荷台用補助部品

フエンダー・工具箱・タンク・タイヤ・ガン

バンディング部材(アルミ・ポリ材料含む)

バンディング部品

荷役部品

ランプ・電装部品

保安部品

補修部品

ダンプ部品

導風板

素材

ステンレス平板②

SUS430

■片面#400研磨

コードNO	商品名	材質	板厚	幅	長さ	表面処理/ビニール	1枚重量kg
4360610	ステンレス平板	SUS430	0.6	× 1000	× 2000	#400研磨/SG	9.24
4360814	〃	〃	0.8	× 1000	× 2000	〃	12.3
4361017	〃	〃	1.0	× 1000	× 2000	〃	15.4
4361211	〃	〃	1.2	× 1000	× 2000	〃	18.5
4361512	〃	〃	1.5	× 1000	× 2000	〃	23.1
4362016	〃	〃	2.0	× 1000	× 2000	〃	30.8
	ステンレス平板	SUS430	0.6	× 1219	× 2438	#400研磨/SG	13.7
4360843	〃	〃	0.8	× 1219	× 2438	〃	18.3
4361046	〃	〃	1.0	× 1219	× 2438	〃	22.9
4361240	〃	〃	1.2	× 1219	× 2438	〃	27.5
4361541	〃	〃	1.5	× 1219	× 2438	〃	34.3
4362045	〃	〃	2.0	× 1219	× 2438	〃	45.8

■片面ウロコ研磨

コードNO	商品名	材質	板厚	幅	長さ	表面処理/ビニール	1枚重量kg
4340614	ステンレス平板	SUS430	0.6	× 1000	× 2000	ウロコ研磨/SPV白	9.24
4340818	〃	〃	0.8	× 1000	× 2000	〃	12.3
4341011	〃	〃	1.0	× 1000	× 2000	〃	15.4
4341215	〃	〃	1.2	× 1000	× 2000	〃	18.5
4341516	〃	〃	1.5	× 1000	× 2000	〃	23.1
4342010	〃	〃	2.0	× 1000	× 2000	〃	30.8
	ステンレス平板	SUS430	0.6	× 1219	× 2438	ウロコ研磨/SPV白	13.7
4340847	〃	〃	0.8	× 1219	× 2438	〃	18.3
4341040	〃	〃	1.0	× 1219	× 2438	〃	22.9
4341244	〃	〃	1.2	× 1219	× 2438	〃	27.5
4341545	〃	〃	1.5	× 1219	× 2438	〃	34.3
4342049	〃	〃	2.0	× 1219	× 2438	〃	45.8

中間鋼種 (NSSC180)

■2B材

コードNO	商品名	材質	板厚	幅	長さ	表面処理/ビニール	1枚重量kg
4320022	ステンレス平板	NSSC180	0.8	× 1219	× 2438	2B/SPV白	18.3
4320023	〃	〃	1.0	× 1219	× 2438	〃	22.9
4320024	〃	〃	1.2	× 1219	× 2438	〃	27.5
4320025	〃	〃	1.5	× 1219	× 2438	〃	34.3
4320026	〃	〃	2.0	× 1219	× 2438	〃	45.8

■片面#400研磨

コードNO	商品名	材質	板厚	幅	長さ	表面処理/ビニール	1枚重量kg
4320062	ステンレス平板	NSSC180	0.8	× 1219	× 2438	#400研磨/SPV白	18.3
4320063	〃	〃	1.0	× 1219	× 2438	〃	22.9
4320064	〃	〃	1.2	× 1219	× 2438	〃	27.5
4320065	〃	〃	1.5	× 1219	× 2438	〃	34.3
4320066	〃	〃	2.0	× 1219	× 2438	〃	45.8

※商品の在庫・納期をご確認ください。

※上記以外のサイズも取り寄せ可能ですのでお問い合わせください。

ステンレス デザインエッチング板①

※柄、サイズによっては受注生産になります。ご注文の際にはロット枚数、納期をご確認ください。

■(P304)

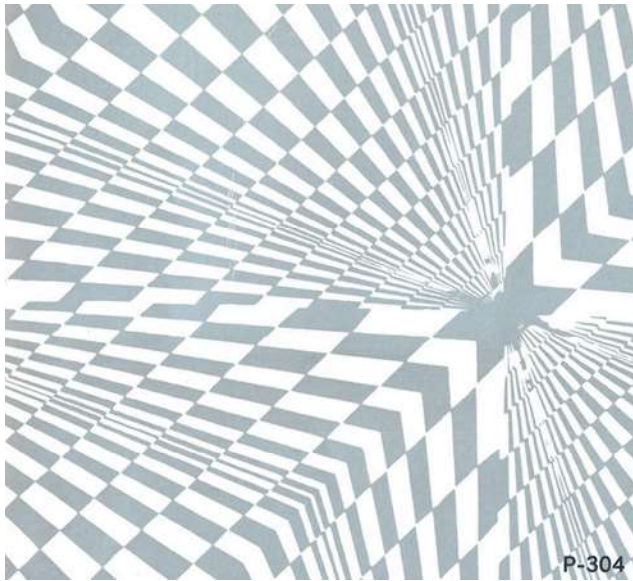

P-304

コードNO	品名・サイズ・デザイン名	重量kg
廃番 4310372	SUS304 0.6t 1219×2438 P304	14.1
4310385	SUS304 0.8t 1219×2438 P304	18.9
4310398	SUS304 1.0t 1219×2438 P304	23.6
4310408	SUS304 1.2t 1219×2438 P304	28.3
4310411	SUS304 1.5t 1219×2438 P304	35.4
4310424	SUS304 2.0t 1219×2438 P304	47.1

■(カサブランカ)



カサブランカ

コードNO	品名・サイズ・デザイン名	重量kg
廃番 4312260	SUS304 0.6t 1219×2438 カサブランカ	14.1
4312273	SUS304 0.8t 1219×2438 カサブランカ	18.9
4312286	SUS304 1.0t 1219×2438 カサブランカ	23.6
4312299	SUS304 1.2t 1219×2438 カサブランカ	28.3
4312309	SUS304 1.5t 1219×2438 カサブランカ	35.4
4312312	SUS304 2.0t 1219×2438 カサブランカ	47.1

■(サクラ パートⅠ)



サクラパートⅠ

コードNO	品名・サイズ・デザイン名	重量kg
廃番 4311067	SUS304 0.6t 1219×2438 サクラ パートⅠ	14.1
4311083	SUS304 0.8t 1219×2438 サクラ パートⅠ	18.9
4311339	SUS304 1.0t 1219×2438 サクラ パートⅠ	23.6
4311342	SUS304 1.2t 1219×2438 サクラ パートⅠ	28.3
4311355	SUS304 1.5t 1219×2438 サクラ パートⅠ	35.4
4311368	SUS304 2.0t 1219×2438 サクラ パートⅠ	47.1

■(サクラ パートⅡ) **廃番**

サクラパートⅡ

コードNO	品名・サイズ・デザイン名	重量kg
4311371	SUS304 0.6t 1219×2438 サクラ パートⅡ	14.1
4311384	SUS304 0.8t 1219×2438 サクラ パートⅡ	18.9
4311397	SUS304 1.0t 1219×2438 サクラ パートⅡ	23.6
4311407	SUS304 1.2t 1219×2438 サクラ パートⅡ	28.3
4311410	SUS304 1.5t 1219×2438 サクラ パートⅡ	35.4
4311423	SUS304 2.0t 1219×2438 サクラ パートⅡ	47.1

荷台用部品

荷台用補助部品

フエンダー・工具箱・タンク・タイヤ・ランガー

バンディング部材 (アルミ・ポリ材含む)

バンディング部品

荷役部品

ランプ・電装部品

保安部品

補修部品

ダンプ部品

導風板

素材

ステンレス デザインエッチング板②

※柄、サイズによっては受注生産になります。ご注文の際にはロット枚数、納期をご確認ください。

■(パピヨン)

廃番



パピヨン

コードNO	品名・サイズ・デザイン名	重量kg
4311096	SUS304 0.6t 1219×2438 パピヨン	14.1
4311106	SUS304 0.8t 1219×2438 パピヨン	18.9
4311119	SUS304 1.0t 1219×2438 パピヨン	23.6
4311122	SUS304 1.2t 1219×2438 パピヨン	28.3
4311135	SUS304 1.5t 1219×2438 パピヨン	35.4
4311148	SUS304 2.0t 1219×2438 パピヨン	47.1

■(ブーゲンビリア)



ブーゲンビリア

コードNO	品名・サイズ・デザイン名	重量kg
4310068	SUS304 0.6t 1219×2438 ブーゲンビリア	14.1
4310084	SUS304 0.8t 1219×2438 ブーゲンビリア	18.9
4312008	SUS304 0.8t 1219×2750 ブーゲンビリア	21.3
4310330	SUS304 1.0t 1219×2438 ブーゲンビリア	23.6
4310343	SUS304 1.2t 1219×2438 ブーゲンビリア	28.3
4310152	SUS304 1.5t 1219×2438 ブーゲンビリア	35.4
4310204	SUS304 2.0t 1219×2438 ブーゲンビリア	47.1

廃番

■(バラ パートI)

廃番



バラパートI

コードNO	品名・サイズ・デザイン名	重量kg
4311151	SUS304 0.6t 1219×2438 バラ パートI	14.1
4311164	SUS304 0.8t 1219×2438 バラ パートI	18.9
4311177	SUS304 1.0t 1219×2438 バラ パートI	23.6
4311180	SUS304 1.2t 1219×2438 バラ パートI	28.3
4311193	SUS304 1.5t 1219×2438 バラ パートI	35.4
4311203	SUS304 2.0t 1219×2438 バラ パートI	47.1

■(バラ パートII)

廃番

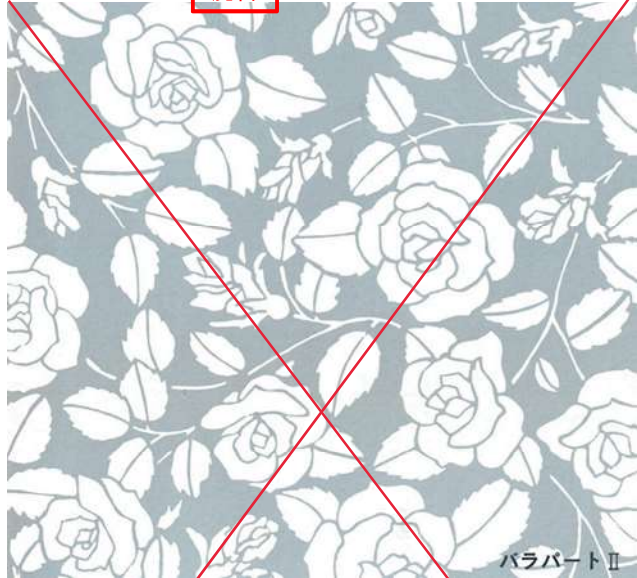

バラパートII

コードNO	品名・サイズ・デザイン名	重量kg
4312118	SUS304 0.6t 1219×2438 バラ パートII	14.1
4312105	SUS304 0.8t 1219×2438 バラ パートII	18.9
4312189	SUS304 1.0t 1219×2438 バラ パートII	23.6
4312192	SUS304 1.2t 1219×2438 バラ パートII	28.3
4312202	SUS304 1.5t 1219×2438 バラ パートII	35.4
4312215	SUS304 2.0t 1219×2438 バラ パートII	47.1

荷台用部品

荷台用補助部品

フエンダー・工具箱・タンク・タイヤンガー

バンディング部材
(アルミ・ポリ素材含む)

バンディング部品

荷役部品

ランプ・電装部品

保安部品

補修部品

ダンプ部品

導風板

素材

ステンレス フラットバー①

フラットバー-SUS304・316・316L

■単位:mm

サイズ 厚さ×幅	長さ	Kg/P		COLD			HOT
		304	316 316L	コールド	H L	400 研磨	
2 × 6	2,000	0.19		●			
	4,000	0.38		●			
2 × 8	2,000	0.254		●			
	4,000	0.508		●			
2 × 9	2,000	0.286		●			
	4,000	0.572		●			
2 × 10	3,000	0.477		●			
	4,000	0.636		●			
2 × 12	4,000	0.76		●			
2 × 15	4,000	0.952		●			●
2 × 20	4,000	1.27		●			●
2 × 25	4,000	1.58		●			●
2 × 30	4,000	1.90		●			●
2 × 32	4,000	2.03		●			●
2 × 38	4,000	2.41		●			●
2 × 40	4,000	2.54		●			●
2 × 50	4,000	3.17		●			●
3 × 3	2,000	0.142		●			
	3,000	0.213		●			
3 × 5	2,000	0.238		●			
	3,000	0.357		●			
3 × 6	3,000	0.429		●			
	4,000	0.572		●			
3 × 7	3,000	0.501		●			
	4,000	0.668		●			
3 × 8	3,000	0.57		●			
	4,000	0.76		●			
3 × 9	3,000	0.642		●			
	4,000	0.856		●			
3 × 10	4,000	0.952		●	●		●
3 × 12	4,000	1.14		●	●		●
3 × 13	4,000	1.24		●	●		●
3 × 15	4,000	1.43		●	●	●	●
3 × 16	4,000	1.52		●	●		●
3 × 19	4,000	1.81		●	●		●
3 × 20	4,000	1.90	1.92	●	●	●	●
3 × 22	4,000	2.09		●	●		●
3 × 25	4,000	2.38	2.39	●	●	●	●
3 × 30	4,000	2.86	2.87	●	●	●	●
3 × 32	4,000	3.04	3.06	●	●	●	●
3 × 35	4,000	3.33		●	●		●
3 × 38	4,000	3.62	3.64	●	●	●	●
3 × 40	4,000	3.81	3.83	●	●	●	●
3 × 42	4,000	4.00		●	●		●
3 × 45	4,000	4.28		●	●		●
3 × 48	4,000	4.56		●	●		●
3 × 50	4,000	4.76	4.80	●	●	●	●
3 × 60	4,000	5.72		●	●	●	●
3 × 65	4,000	6.20		●	●		●
3 × 75	4,000	7.12		●	●		●
3 × 100	4,000	9.52		●	●		●
3 × 110	4,000	10.5		●			
3 × 120	4,000	11.4		●			
3 × 125	4,000	11.9		●			
3 × 130	4,000	12.4		●			
3 × 140	4,000	13.3		●			
3 × 150	4,000	14.3		●			
4 × 4	3,000	0.381		●			
	4,000	0.508		●			

●=コールド ●=HL ●=#400 ●=未研磨
※316,316LはHOT品のみです。

■単位:mm

サイズ 厚さ×幅	長さ	Kg/P		COLD			HOT
		304	316 316L	コールド	H L	400 研磨	
4 × 4	4,000	0.508		●			
4 × 9	4,000	1.14		●			
4 × 10	4,000	1.27		●	●		
4 × 11	4,000	1.40		●	●		●
4 × 13	4,000	1.65		●	●		
4 × 15	4,000	1.90		●	●	●	●
4 × 16	4,000	2.03		●	●		
4 × 19	4,000	2.41		●	●		●
4 × 20	4,000	2.54		●	●	●	●
4 × 22	4,000	2.79		●	●		●
4 × 25	4,000	3.17	3.19	●	●	●	●
4 × 30	4,000	3.81	3.83	●	●	●	●
4 × 32	4,000	4.08		●	●	●	●
4 × 35	4,000	4.44		●	●		●
4 × 38	4,000	4.84		●	●	●	●
4 × 40	4,000	5.08	5.12	●	●	●	●
4 × 45	4,000	5.72		●	●		●
4 × 50	4,000	6.36	6.40	●	●	●	●
4 × 60	4,000	7.60		●	●		●
4 × 65	4,000	8.24		●	●		●
4 × 75	4,000	9.52		●	●		●
4 × 90	4,000	11.4		●	●		●
4 × 100	4,000	12.7		●	●		●
5 × 5	4,000	0.792		●	●		
	4,000	1.27		●			
5 × 9	4,000	1.43		●			
5 × 10	4,000	1.59		●	●		
5 × 12	4,000	1.90		●	●		
5 × 13	4,000	2.06		●	●		
5 × 15	4,000	2.38		●	●	●	●
5 × 16	4,000	2.54		●	●		
5 × 19	4,000	3.01		●	●		●
5 × 20	4,000	3.17	3.19	●	●	●	●
5 × 22	4,000	3.49		●	●		●
5 × 25	4,000	3.96	3.99	●	●	●	●
5 × 30	4,000	4.76	4.80	●	●	●	●
5 × 32	4,000	5.08		●	●	●	●
5 × 34	4,000	5.40		●	●		
5 × 35	4,000	5.56		●	●		●
5 × 38	4,000	6.04		●	●	●	●
5 × 40	4,000	6.36	6.40	●	●	●	●
5 × 50	4,000	7.92	8.00	●	●	●	●
5 × 60	4,000	9.52		●	●		●
5 × 65	4,000	10.3		●	●		●
5 × 75	4,000	11.9		●	●		●
5 × 90	4,000	14.3		●	●		●
5 × 100	4,000	15.8		●	●		●
5 × 130	4,000	20.6		●			
5 × 150	4,000	23.8		●			
6 × 6	4,000	1.14		●	●		
	4,000	1.71		●			
6 × 10	4,000	1.90		●	●		
6 × 12	4,000	2.28		●	●		
6 × 13	4,000	2.48		●	●		
6 × 15	4,000	2.86		●	●	●	●
6 × 16	4,000	3.04		●	●		●

※メーカー在庫品は変更になる場合があります。都度お問い合わせください。

荷台用部品
荷台用補助部品
フエンダー・工具箱・タンク・タイヤ・ハンガー
バンディング部材
バンディング部品
荷役部品
ランプ・電装部品
保安部品
補修部品
ダンプ部品
導風板
素材

ステンレス フラットバー②

フラットバーSUS304・316・316L

■単位:mm

サイズ 厚さ×幅	長さ	Kg/P		COLD			HOT
		304	316 316L	コールド	H L	400 研磨	
6 × 18	4,000	3.42		●	●		
6 × 19	4,000	3.62		●	●		●
6 × 20	4,000	3.81		●	●	●	●
6 × 22	4,000	4.20		●	●		●
6 × 25	4,000	4.76	4.80	●	●	●	●
6 × 30	4,000	5.72	5.76	●	●	●	●
6 × 32	4,000	6.08	6.12	●	●	●	●
6 × 35	4,000	6.68		●	●		●
6 × 38	4,000	7.24	7.28	●	●	●	●
6 × 40	4,000	7.60	7.68	●	●	●	●
6 × 42	4,000	8.00		●	●		●
6 × 45	4,000	8.56		●	●	●	●
6 × 48	4,000	9.12		●	●	●	●
6 × 50	4,000	9.52	9.56	●	●	●	●
	6,000	14.3		●	●		●
6 × 60	4,000	11.4		●	●	●	●
	4,000	12.4	12.4	●	●	●	●
6 × 65	4,000	12.4		●	●		●
	6,000	18.5		●	●		●
6 × 70	4,000	13.3		●	●		●
6 × 75	4,000	14.3	14.4	●	●	●	●
	6,000	21.4		●	●		●
6 × 90	4,000	17.1		●	●		●
	4,000	19.0	19.2	●	●	●	●
6 × 100	6,000	28.6		●	●		●
6 × 110	4,000	20.9		●	●		●
6 × 120	4,000	22.8		●	●		●
6 × 125	4,000	23.8		●	●		●
6 × 130	4,000	24.8		●	●		●
6 × 140	4,000	26.6		●	●		●
6 × 150	4,000	28.6		●	●		●
7 × 7	4,000	1.56		●	●		
7 × 20	4,000	4.44					●
8 × 8	4,000	2.03		●	●	●	
8 × 10	4,000	2.54		●	●		
8 × 16	4,000	4.08		●	●		●
8 × 30	4,000	7.60					●
8 × 32	4,000	8.12		●	●		●
8 × 38	4,000	9.64		●	●		●
8 × 40	4,000	10.2					●
8 × 50	4,000	12.7		●	●		●
8 × 65	4,000	16.5					●
8 × 75	4,000	19.0					●
8 × 100	4,000	25.4					●
9 × 9	4,000	2.57		●	●	●	
9 × 13	4,000	3.71		●	●		●
9 × 15	4,000	4.28		●	●		●
9 × 16	4,000	4.56		●	●		●
9 × 19	4,000	5.44		●	●		●
9 × 20	4,000	5.72		●	●	●	●
9 × 22	4,000	6.28		●	●		●
9 × 25	4,000	7.12	7.20	●	●	●	●
	6,000	10.7		●	●		●
9 × 30	4,000	8.56	8.60	●	●	●	●
	6,000	12.8		●	●		●
9 × 32	4,000	9.12	9.20	●	●	●	●

●=コールド ●=HL ●=#400 ●=未研磨
※316,316LはHOT品のみです。

■単位:mm

サイズ 厚さ×幅	長さ	Kg/P		COLD			HOT
		304	316 316L	コールド	H L	400 研磨	
9 × 32	6,000	13.7		●	●		
9 × 35	4,000	10.0					●
9 × 38	4,000	10.8	10.9	●	●	●	●
	6,000	16.3		●	●		●
9 × 40	4,000	11.4		●	●	●	●
	6,000	17.1		●	●		●
9 × 45	4,000	12.8					●
9 × 50	4,000	14.3	14.4	●	●	●	●
	6,000	21.4		●	●		●
9 × 55	4,000	15.7					●
9 × 60	4,000	17.1		●	●		●
9 × 65	4,000	18.6	18.7	●	●	●	●
	6,000	27.8		●	●		●
9 × 75	4,000	21.4	21.6	●	●	●	●
	6,000	32.1		●	●		●
9 × 90	4,000	25.7	25.8	●	●		●
	4,000	28.6	28.7	●	●		●
9 × 100	6,000	42.8		●	●		●
	4,000	35.7		●	●		●
9 × 125	4,000	35.7		●	●		●
	6,000	53.5					●
9 × 150	4,000	42.8		●	●		●
	6,000	64.2					●
9 × 200	4,000	57.2		●	●		●
9 × 250	4,000	71.2		●	●		●
9 × 300	4,000	85.6		●			●
10 × 10	4,000	3.17		●	●	●	●
10 × 15	4,000	4.76		●	●		●
10 × 19	4,000	6.04		●	●		●
10 × 20	4,000	6.36		●	●	●	●
10 × 25	4,000	7.92		●	●	●	●
10 × 30	4,000	9.52		●	●	●	●
10 × 32	4,000	10.2		●	●	●	●
10 × 35	4,000	11.1					●
10 × 38	4,000	12.0		●	●	●	●
10 × 40	4,000	12.7		●	●	●	●
10 × 50	4,000	15.8	16.0	●	●	●	●
10 × 65	4,000	20.6		●	●	●	●
10 × 75	4,000	23.8		●	●	●	●
10 × 100	4,000	31.7	31.9	●	●		●
10 × 125	4,000	39.6		●	●		●
10 × 150	4,000	47.6		●	●		●
10 × 200	4,000	63.6		●	●		●
10 × 250	4,000	79.2		●	●		●
10 × 300	4,000	95.2		●			●
12 × 12	4,000	4.56		●	●	●	●
12 × 14	4,000	5.32		●			●
12 × 15	4,000	5.72					●
12 × 16	4,000	6.08		●	●		●
12 × 19	4,000	7.24		●	●		●
12 × 20	4,000	7.60		●	●	●	●
12 × 25	4,000	9.52	9.56	●	●	●	●
12 × 28	4,000	10.6					●
12 × 30	4,000	11.4		●	●	●	●
	6,000	18.3		●	●		●
12 × 32	4,000	12.2	12.2	●	●	●	●
	6,000	18.3		●	●		●
12 × 35	4,000	13.3		●	●		●

※メーカー在庫品は変更になる場合があります。都度お問い合わせください。

ステンレス フラットバー③

フラットバー-SUS304・316・316L

■単位:mm

サイズ 厚さ×幅	長さ	Kg/P		COLD			HOT
		304	316 316L	コールド	H L	400 研磨	
12 × 38	4,000	14.5	14.6	●	●	●	●
	6,000	21.7		●	●	●	●
12 × 40	4,000	15.2		●	●	●	●
	6,000	22.9		●	●	●	●
12 × 50	4,000	19.0	19.2	●	●	●	●
	6,000	28.6		●	●	●	●
12 × 65	4,000	24.8	24.9	●	●	●	●
	6,000	37.1		●	●	●	●
12 × 70	4,000	26.6		●	●	●	●
	6,000	37.1		●	●	●	●
12 × 75	4,000	28.6	28.7	●	●	●	●
	6,000	42.8		●	●	●	●
12 × 90	4,000	34.2		●	●	●	●
	6,000	57.1		●	●	●	●
12 × 100	4,000	38.1	38.3	●	●	●	●
	6,000	57.1		●	●	●	●
12 × 125	4,000	47.6		●	●	●	●
	6,000	71.4		●	●	●	●
12 × 150	4,000	57.2		●	●	●	●
	6,000	85.8		●	●	●	●
12 × 200	4,000	76.0		●	●	●	●
12 × 250	4,000	95.2		●	●	●	●
12 × 300	4,000	114		●	●	●	●
13 × 13	4,000	5.36		●	●	●	●
14 × 14	4,000	6.20		●	●	●	●
15 × 15	4,000	7.12		●	●	●	●
16 × 16	4,000	8.12		●	●	●	●
16 × 19	4,000	9.64		●	●	●	●
16 × 20	4,000	10.2		●	●	●	●
16 × 25	4,000	12.7	12.8	●	●	●	●
16 × 30	4,000	15.2		●	●	●	●
16 × 32	4,000	16.2	16.4	●	●	●	●
16 × 35	4,000	17.8		●	●	●	●
16 × 38	4,000	19.3	19.4	●	●	●	●
16 × 40	4,000	20.3		●	●	●	●
16 × 50	4,000	25.4	25.5	●	●	●	●
	6,000	38.0		●	●	●	●
16 × 65	4,000	33.0	33.2	●	●	●	●
	6,000	49.5		●	●	●	●
16 × 75	4,000	38.1	38.3	●	●	●	●
	6,000	57.1		●	●	●	●
16 × 90	4,000	45.6		●	●	●	●
16 × 100	4,000	50.8	51.2	●	●	●	●
	6,000	76.2		●	●	●	●
16 × 125	4,000	63.6		●	●	●	●
	6,000	95.4		●	●	●	●
16 × 150	4,000	76.0		●	●	●	●
	6,000	114		●	●	●	●
16 × 200	4,000	102		●	●	●	●
16 × 250	4,000	127		●	●	●	●
16 × 300	4,000	152		●	●	●	●
19 × 19	4,000	11.4	11.5	●	●	●	●
19 × 25	4,000	15.1		●	●	●	●
19 × 30	4,000	18.1		●	●	●	●
19 × 32	4,000	19.3		●	●	●	●

●=コールド ●=HL ●=#400 ●=未研磨
 ※316,316LはHOT品のみです。

■単位:mm

サイズ 厚さ×幅	長さ	Kg/P		COLD			HOT
		304	316 316L	コールド	H L	400 研磨	
19 × 35	4,000	21.1					●
19 × 38	4,000	22.9		●	●	●	●
19 × 40	4,000	24.1					●
19 × 50	4,000	30.1	30.3	●	●	●	●
19 × 65	4,000	39.2	39.4	●	●		●
19 × 75	4,000	45.2	45.6	●	●		●
19 × 90	4,000	54.4					●
19 × 100	4,000	60.4	60.8	●	●		●
19 × 125	4,000	75.2		●	●		●
19 × 150	4,000	90.4		●	●		●
19 × 200	4,000	120		●	●		●
19 × 250	4,000	151		●	●		●
19 × 300	4,000	181		●			●
20 × 20	4,000	12.7	12.8	●	●	●	●
22 × 22	4,000	15.4	15.4	●	●		●
22 × 25	4,000	17.4					●
22 × 30	4,000	20.9					●
22 × 32	4,000	22.3		●			●
22 × 35	4,000	24.4					●
22 × 38	4,000	26.5		●			●
22 × 40	4,000	27.9					●
22 × 45	4,000	31.4					●
22 × 50	4,000	34.9		●			●
22 × 65	4,000	45.2		●			●
22 × 75	4,000	52.4		●			●
22 × 100	4,000	69.6		●			●
22 × 125	4,000	87.2					●
22 × 150	4,000	105					●
22 × 200	4,000	140					●
22 × 250	4,000	174					●
22 × 300	4,000	209					●
25 × 25	4,000	19.8	20.0	●	●	●	●
25 × 32	4,000	25.4		●			●
25 × 35	4,000	27.8					●
25 × 38	4,000	30.1		●			●
25 × 40	4,000	31.7					●
25 × 50	4,000	39.6		●			●
25 × 60	4,000	47.6					●
25 × 65	4,000	51.6		●			●
25 × 75	4,000	59.6		●			●
25 × 100	4,000	79.2		●			●
25 × 125	4,000	99.2		●			●
25 × 150	4,000	119		●			●
25 × 200	4,000	158		●			●
25 × 250	4,000	198		●			●
25 × 300	4,000	238		●			●
26 × 26	4,000	21.4		●			●
28 × 28	4,000	24.9		●			●
30 × 30	4,000	28.6	28.7	●			●
30 × 50	4,000	47.6		●			●
30 × 55	4,000	52.4		●			●
30 × 65	4,000	62.0		●			●

※メーカー在庫品は変更になる場合があります。都度お問い合わせください。

荷台用部品

荷台用補助部品

フエンダー・工具箱・タンク・タイヤ・ハンガー

バンディング部材(アルミ・ポリ材料含む)

バンディング部品

荷役部品

ランプ・電装部品

保安部品

補修部品

ダンプ部品

導風板

素材

ステンレス フラットバー④

フラットバーSUS304・316・316L

■単位:mm

サイズ 厚さ×幅	長さ	Kg/P		COLD			HOT
		304	316 316L	コールド	H L	400 研磨	
30 × 75	4,000	71.2		●			●
30 × 100	4,000	95.2		●			●
30 × 125	4,000	119					●
30 × 150	4,000	143					●
30 × 200	4,000	190					●
30 × 250	4,000	238					●
30 × 300	4,000	286					●
32 × 32	4,000	32.5	32.7	●			●
35 × 50	4,000	55.6		●			●
35 × 55	4,000	61.2					●
35 × 65	4,000	72.0		●			●
35 × 75	4,000	83.2		●			●
35 × 100	4,000	111		●			●
35 × 125	4,000	139					●
35 × 150	4,000	166					●
36 × 36	4,000	41.2		●			●
38 × 38	4,000	45.8	46.0	●			●
40 × 40	4,000	50.8	51.2	●			●
40 × 50	4,000	63.6					●
40 × 65	4,000	82.4					●
40 × 75	4,000	95.2					●
40 × 100	4,000	127					●
40 × 125	4,000	158					●
40 × 150	4,000	190					●
42 × 42	4,000	56.0	56.4				●
45 × 45	4,000	64.4		●			●
50 × 50	4,000	79.2	79.8	●			●

●=コールド ●=HL ●=#400 ●=未研磨
 ※316、316LはHOT品のみです。

■単位:mm

サイズ 厚さ×幅	長さ	Kg/P		COLD			HOT
		304	316 316L	コールド	H L	400 研磨	
50 × 65	4,000	103					●
50 × 75	4,000	119					●
50 × 100	4,000	158					●
50 × 125	4,000	198					●
50 × 150	4,000	238					●
55 × 55	4,000	96.0		●			●
60 × 60	4,000	114		●			●
60 × 75	4,000	143					●
60 × 100	4,000	190					●
60 × 125	4,000	238					●
60 × 150	4,000	286					●
65 × 65	4,000	134		●			●
70 × 70	4,000	156					●
70 × 100	4,000	222					●
70 × 125	4,000	278					●
70 × 150	4,000	333					●
75 × 75	4,000	178					●
80 × 100	4,000	254					●
80 × 125	4,000	317					●
80 × 150	4,000	381					●
90 × 90	4,000	257					●
90 × 100	4,000	286					●
90 × 125	4,000	357					●
90 × 150	4,000	428					●
100 × 100	4,000	317					●
100 × 125	4,000	396					●
100 × 150	4,000	476					●

※メーカー在庫品は変更になる場合があります。都度お問い合わせください。

ラウンドフラットバーSUS304

■単位:mm

サイズ 厚さ×幅	長さ	R寸法	Kg/P	研磨	
3 × 15	4,000	1.5R	1.36	●	●
3 × 20	4,000	1.5R	1.84	●	●
3 × 25	4,000	1.5R	2.32	●	●
3 × 30	4,000	1.5R	2.79	●	●
3 × 32	4,000	1.5R	2.98	●	●
3 × 40	4,000	1.5R	3.74	●	●
3 × 50	4,000	1.5R	4.72	●	●
3 × 65	4,000	1.5R	6.12	●	●
3 × 75	4,000	1.5R	7.08	●	●
3 × 100	4,000	1.5R	9.48	●	●
6 × 25	4,000	3.0R	4.48	●	●
6 × 30	4,000	3.0R	5.44	●	●

●=HL ●=#400

■単位:mm

サイズ 厚さ×幅	長さ	R寸法	Kg/P	研磨	
6 × 40	4,000	3.0R	7.36	●	●
6 × 50	4,000	3.0R	9.24	●	●
6 × 65	4,000	3.0R	12.1	●	●
6 × 75	4,000	3.0R	14.0	●	●
6 × 100	4,000	3.0R	18.8	●	●
9 × 30	4,000	4.5R	8.0	●	●
9 × 40	4,000	4.5R	10.8	●	●
9 × 50	4,000	4.5R	13.7	●	●
9 × 65	4,000	4.5R	18.0	●	●
9 × 75	4,000	4.5R	20.8	●	●
9 × 100	4,000	4.5R	28.0	●	●



3mmは全て1.5R
 6mmは全て3.0R
 9mmは全て4.5R

※メーカー在庫品は変更になる場合があります。都度お問い合わせください。

ステンレス丸棒①

丸棒 SUS304・303・316

※メーカー在庫品は変更になる場合があります。都度お問い合わせください。

サイズ外径 mm	m重量		304直棒		304 酸洗丸棒	304 HL丸棒	ピーリング			引抜き			センタレス	
	304・303	316	未研磨	磨き			304	303	316	304	303	316	304	303
2	0.025	0.025	●	●						●	●	●	●	●
2.5	0.039		●	●						●			●	●
3	0.056	0.056	●	●						●	●	●	●	●
3.5	0.076									●			●	●
4	0.100	0.100	●	●						●	●	●	●	●
5	0.156	0.157	●	●						●	●	●	●	●
6	0.224	0.226	●	●						●	●	●	●	●
7	0.305		●	●						●	●		●	●
8	0.399	0.401	●	●	●	●	●			●	●	●	●	●
9	0.504	0.508	●	●	●	●	●	●		●	●	●	●	●
10	0.623	0.627	●	●	●	●	●	●	●	●	●	●	●	●
11	0.754	0.758			●					●	●	●	●	●
12	0.897	0.903	●	●	●	●	●	●		●	●	●	●	●
13	1.05	1.059	●	●	●	●	●	●		●	●		●	●
14	1.22				●	●				●	●		●	●
15	1.40				●	●				●	●		●	●
	1.42	1.42					●							
16	1.59				●	●				●	●		●	●
	1.61	1.62					●	●	●					
17	1.80				●					●	●		●	●
18	2.02				●					●	●		●	●
	2.03	2.05					●							
19	2.25				●	●				●	●		●	●
	2.27	2.28					●	●	●					
20	2.49				●	●				●	●		●	●
	2.51	2.53					●	●	●					
22	3.01				●	●				●	●		●	●
	3.03	3.05					●	●	●					
24	3.59							●			●			
	3.61	3.63							●					
25	3.89				●	●				●	●		●	●
	3.92	3.94					●	●	●					
26	4.21						●						●	
	4.25						●							
28	4.88									●	●		●	
	4.93	4.98					●	●	●					
30	5.61									●			●	●
	5.65	5.69					●	●	●		●			
32	6.38									●	●			
	6.43	6.47					●	●	●					
35	7.63									●	●		●	●
	7.68	7.73					●							
36	8.13						●			●				
38	8.99									●				
	9.06	9.11					●	●	●					
40	9.97									●			●	●
	10.0	10.1					●	●	●					
42	11.0									●				
	11.1	11.1					●	●	●					
45	12.6									●			●	
	12.7	12.8					●	●	●					
46	13.2						●							

●=HL ●=未研磨 ●=コールド

●直棒長さ:2m、4m ●酸洗、HL丸棒長さ:4m ●ピーリング長さ:4m(一部5m、6mもあり)
 ●引抜き:4m(一部5m、5.5m、6mもあり) ●センタレス:SUS304 2m、SUS303 2.1m

荷台用部品

荷台用補助部品

フエンダー・工具箱・タンク・クイック・イヤー・ガー

バンディング部材(アルミ・オリー材含む)

バンディング部品

荷役部品

ランプ・電装部品

保安部品

補修部品

ダンプ部品

導風板

素材

ステンレス丸棒②

丸棒 SUS304・303・316

※メーカー在庫品は変更になる場合があります。都度お問い合わせください。

サイズ外径 mm	m重量		304直棒		304 酸洗丸棒	304 HL丸棒	ピーリング			引抜き			センタレス	
	304・303	316	未研磨	磨き			304	303	316	304	303	316	304	303
48	14.3										●			
	14.4	14.5					●	●	●					
50	15.6										●			●
	15.6	15.7					●	●	●					
55	18.8										●			
	18.9	19.0					●	●	●					
60	22.4										●			
	22.5	22.7					●	●	●					
65	26.3										●			
	26.4	26.6					●	●	●					
70	30.5										●			
	30.6	30.8					●	●	●					
75	35.0										●			
	35.2	35.4					●	●	●					
80	39.9										●			
	40.0	40.2					●	●	●					
85	45.3	45.5					●	●	●					
90	50.7	51.0					●	●	●					
95	56.5	56.9					●	●	●					
100	62.6	63.0					●	●	●					
105	69.0						●							
110	75.7	76.2					●	●	●					
115	82.7						●							
120	90.1	90.7					●	●	●					
125	97.7						●							
130	106	107					●	●	●					
135	114						●							
140	123	124					●	●	●					
145	132						●							
150	141	142					●	●	●					
155	152						●							
160	161	162					●	●	●					
170	182	183					●	●	●					
180	204	205					●	●	●					
190	227	229					●	●	●					
200	252	253					●	●	●					
210	277						●							
220	304						●							
230	332						●							
240	362						●							
250	392						●							

●=HL ●=未研磨 ●=コールド

●直棒長さ:2m、4m ●酸洗、HL丸棒長さ:4m ●ピーリング長さ:4m(一部5m、6mもあり)

●引抜き:4m(一部5m、5.5m、6mもあり) ●センタレス:SUS304 2m、SUS303 2.1m

荷台用部品

荷台用補助部品

フエントール・工具箱・
タンク・タイヤ・ガンバン・ウイング部品
(アルミ・ポリ材料含む)

バン・ウイング部品

荷役部品

ランプ・電装部品

保安部品

補修部品

ランプ部品

導風板

素材

ステンレス アングル①

SUS304・316・316L・430(熱間圧延品)

※メーカー在庫品は変更になる場合があります。都度お問い合わせください。

サイズ				SUS304				316・316L				430		
				4,000mm		6,000mm		4,000mm		6,000mm		4,000mm		
肉厚	×	辺	×	辺	Kg/P	研磨	Kg/P	研磨	Kg/P	研磨	Kg/P	研磨	Kg/P	研磨
2	×	30	×	30									3.62	●
2	×	40	×	40									4.88	●
3	×	20	×	20	3.58	● ● ●			3.60	●			3.47	●
3	×	25	×	25	4.52	● ● ●			4.56	●			4.40	●
3	×	30	×	30	5.48	● ● ●	8.22	● ● ●			8.28	●	5.32	●
3	×	35	×	35			9.66	● ● ●						
3	×	40	×	40	7.40	● ● ●	11.1	● ● ●			11.2	●	7.20	●
3	×	45	×	45			12.8	● ● ●						
3	×	50	×	50	9.48	● ● ●	14.2	● ● ●						
4	×	30	×	30			10.6	● ● ●						
4	×	35	×	35			12.6	● ● ●						
4	×	40	×	40	9.64	● ● ●	14.5	● ● ●						
4	×	45	×	45			16.6	● ● ●						
4	×	50	×	50	12.4	● ● ●	18.5	● ● ●			18.5	●		
4	×	55	×	55			20.4	● ● ●						
5	×	30	×	30			13.1	● ● ●						
5	×	35	×	35			15.5	● ● ●						
5	×	40	×	40	11.9	● ● ●	17.9	● ● ●			17.9	●		
5	×	45	×	45			20.5	● ● ●						
5	×	50	×	50	15.2	● ● ●	22.9	● ● ●			23.0	●		
5	×	60	×	60			27.6	● ● ●						
5	×	65	×	65			30.3	● ● ●						
5	×	70	×	70			32.7	● ● ●						
5	×	75	×	75			35.0	● ● ●						
6	×	30	×	30			15.2	● ● ●						
6	×	35	×	35			18.2	● ● ●						
6	×	40	×	40			21.0	● ● ●						
6	×	45	×	45			24.1	● ● ●						
6	×	50	×	50	17.9	● ● ●	26.9	● ● ●			26.9	●		
6	×	55	×	55			29.8	● ● ●						
6	×	60	×	60			32.6	● ● ●						
6	×	65	×	65	23.9	● ● ●	35.8	● ● ●			35.8	●		
6	×	70	×	70			38.6	● ● ●						
6	×	75	×	75	27.7	● ● ●	41.5	● ● ●			41.5	●		
6	×	80	×	80			44.4	● ● ●						
6	×	90	×	90			50.2	● ● ●						
6	×	100	×	100			55.9	● ● ●						
7	×	70	×	70			44.5	● ● ●						
8	×	50	×	50			34.7	● ● ●						
8	×	60	×	60			42.3	● ● ●						
8	×	65	×	65			46.4	● ● ●						
8	×	70	×	70			50.2	● ● ●						
8	×	75	×	75			54.1	● ● ●						
8	×	80	×	80			57.8	● ● ●						
8	×	90	×	90			66.0	● ● ●						
8	×	100	×	100			73.2	● ● ●						
9	×	50	×	50			38.6	● ● ●						
9	×	60	×	60			47.2	● ● ●						
9	×	65	×	65			51.8	● ● ●						
9	×	70	×	70			56.1	● ● ●						
9	×	75	×	75	40.4	● ● ●	60.6	● ● ●			60.6	●		
9	×	80	×	80			64.8	● ● ●						
9	×	90	×	90			73.8	● ● ●						
9	×	100	×	100			82.2	● ● ●						
9	×	125	×	125			103.0	● ● ●						

● = 全面HL研磨品 ● = 外2面#400 ● = 酸洗仕上品

荷台用部品

荷台用補助部品

フエンダー・工具箱
タンク・タイヤレガーバンディング部材
(アルミ・ポリ材料含む)

バンディング部品

荷役部品

ランプ・電装部品

保安部品

補修部品

ダンプ部品

導風板

素材

ステンレス アングル②

SUS304・316・316L・430(熱間圧延品)

※メーカー在庫品は変更になる場合があります。都度お問い合わせください。

サイズ 肉厚 × 辺 × 辺	SUS304				316・316L				430	
	4,000mm		6,000mm		4,000mm		6,000mm		4,000mm	
	Kg/P	研磨	Kg/P	研磨	Kg/P	研磨	Kg/P	研磨	Kg/P	研磨
10 × 50 × 50			42.5	●						
10 × 60 × 60			52.1	●						
10 × 65 × 65			57.1	●						
10 × 70 × 70			61.8	●						
10 × 75 × 75			66.6	●						
10 × 80 × 80			70.8	●						
10 × 90 × 90			81.0	●						
10 × 100 × 100	60.4	●	90.6	●			60.6	●		
12 × 75 × 75			78.6	●						
12 × 80 × 80			84.0	●						
12 × 90 × 90			96.0	●						
12 × 100 × 100			107.0	●						
12 × 125 × 125			136.0	●						
12 × 130 × 130			142.0	●						
15 × 125 × 125			168.0	●						
15 × 150 × 150			203.0	●						

● = 全面HL研磨品 ● = 外2面 #400 ● = 酸洗仕上品

不等辺アングル SUS304(熱間圧延品・片辺切断品)

サイズ 肉厚 × 辺 × 辺	SUS304 6,000mm	
	Kg/P	研磨
4 × 45 × 30	13.6	●
● 6 × 50 × 30	21.4	●
● 6 × 65 × 50	31.7	●
6 × 75 × 50	34.4	●
7 × 75 × 50	39.5	●
● 9 × 75 × 50	50.0	●
● 6 × 75 × 65	38.8	●
● 9 × 90 × 75	67.2	●
6 × 100 × 75	48.8	●
● 7 × 100 × 75	56.7	●
9 × 100 × 75	71.4	●
6 × 125 × 75	55.9	●
9 × 125 × 75	82.2	●
9 × 150 × 90	99.0	●
12 × 150 × 90	130.0	●

● = 片辺切断品 ● = 未研磨

寸法公差基準表

辺長許容差	20~25 ±1.5	30~50 ±2.0	60~90 ±3.0	100~150 ±4.0
直角度	90° ±2°			
曲がり	1mにつき3mm以下 全長に対して $\frac{3\text{mm} \times \text{全長m}}{1\text{m}}$ 以下			
長さ	+40mm、-0mm			
厚さ	t	20~90	100	125~150
	辺長	3.0~12.0	±0.4	±0.6

■熱間圧延品(等辺アングル)

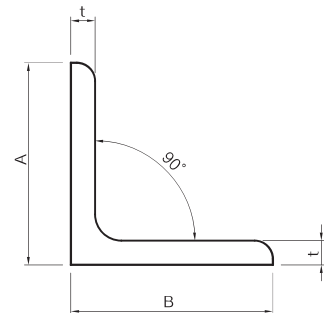

■熱間圧延品(不等辺アングル)

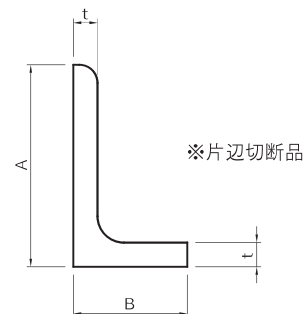

荷台用部品

荷台用補助部品

ファンダー・工具箱・タンク・タイヤンガー

バンウィング部材(アルミ・ポリ材料含む)

バンウィング部材

荷役部品

ランプ・電装部品

保安部品

補修部品

ダンプ部品

導風板

素材

ステンレス化粧パイプ

化粧パイプ SUS304

■単位:mm

サイズ	厚み 長さ	0.8		1.0		1.2		1.5			2.0			3.0			4.0	
		4000	4000	4000	4000	4000	5000	6000	4000	5000	6000	4000	5000	6000	4000	6000		
5		●	●															
6		●	●															
7		●	●															
8		●	●	●														
9		●	●															
10		●	●	●														
12		●	●															
13		●	●	●	●	●	●	●	●	●	●							
13.8				●	●	●	●											
14		●	●															
15		●	●															
16		●	●	●	●	●	●	●	●	●	●	●						
17.3					●	●	●	●	●	●	●	●	●					
19		●	●	●	●	●	●	●	●	●	●	●	●	●				
21.7			●	●	●	●	●	●	●	●	●	●	●	●	●			
22		●	●	●	●	●	●	●	●	●	●	●	●	●				
25		●	●	●	●	●	●	●	●	●	●	●	●	●				
25.4			●	●	●	●			●	●								
27.2			●	●	●	●	●	●	●	●	●	●	●	●	●	●		
32			●	●	●	●	●	●	●	●	●	●	●	●	●	●		
34			●	●	●	●	●	●	●	●	●	●	●	●	●	●		
38			●	●	●	●	●	●	●	●	●	●	●	●	●	●		
42.7				●	●	●	●	●	●	●	●	●	●	●	●	●		
45					●	●			●	●								
48.6				●	●	●	●	●	●	●	●	●	●	●	●	●		
50			●	●	●	●	●	●	●	●	●	●	●	●	●			
50.8					●	●												
60.5					●	●	●	●	●	●	●	●	●	●	●	●		
76.3					●	●		●	●		●	●		●	●	●		
89.1					●	●		●	●		●	●		●	●	●		
101.6					●	●		●	●		●	●		●	●	●		
114.3								●	●		●	●		●	●	●		
139.8								●	●		●	●		●	●	●		
165.2											●	●		●	●	●		
216.3											●	●		●	●	●		

● = HL ● = #400

※メーカー在庫品は変更になる場合があります。都度お問い合わせください。

寸法公差基準表

外径	20mm未満	±0.15
	20mm~50mm	±0.25
	50mm以上	±0.5%
肉厚	1.2mm未満	±0.15
	1.2mm~2.0mm	±0.20
	2.0mm以上	±10%
長さ		-0
		+規定せず
真直度	1mに対し	1.0mm以内

荷台用部品

荷台用補助部品

フエンダー・工具箱・タンク・タイヤパンガー

バンディング部材(アルミ・ポリ材料含む)

バンディング部品

荷役部品

ランプ・電装部品

保安部品

補修部品

ダンプ部品

導風板

素材

ステンレス角パイプ

※メーカー在庫品は変更になる場合があります。都度お問い合わせください。

角パイプ 正方形 SUS304 ■単位:mm

サイズ	厚さ		SUS304						
	長さ		1.0	1.2	1.5	2.0	3.0		
7×7	4,000		● ●						
9×9	3,000		●						
9×9	4,000		● ● ● ●						
10×10	〃		● ● ● ●	● ● ● ●					
12×12	〃		● ● ● ●	● ● ● ● ● ●					
13×13	〃		● ● ● ●	● ● ● ● ● ●					
14×14	〃		● ● ● ●	● ● ● ● ● ●					
16×16	5,000		● ● ● ●	● ● ● ● ● ●	● ● ● ● ● ●				
	6,000				● ● ● ●	● ● ● ●			
19×19	5,000		● ● ● ●	● ● ● ● ● ●	● ● ● ● ● ●	● ● ● ●			
	6,000				● ● ● ●	● ● ● ●			
20×20	5,000			● ● ● ●	● ● ● ● ● ●	● ● ● ●			
21×21	〃		● ● ● ●	● ● ● ● ● ●	● ● ● ● ● ●	● ● ● ●			
22×22	〃		● ● ● ●	● ● ● ● ● ●	● ● ● ● ● ●	● ● ● ●			
24×24	〃		● ● ● ●	● ● ● ● ● ●	● ● ● ● ● ●	● ● ● ●			
25×25	5,000			● ● ● ●	● ● ● ● ● ●	● ● ● ● ● ●	● ● ● ●		
	6,000				● ● ● ●	● ● ● ●			
25.4×25.4	5,000			● ● ● ●	● ● ● ● ● ●	● ● ● ●			
28.6×28.6	〃		● ● ● ●	● ● ● ● ● ●	● ● ● ● ● ●	● ● ● ●			
30×30	5,000			● ● ● ●	● ● ● ● ● ●	● ● ● ● ● ●	● ● ● ●		
	6,000				● ● ● ●	● ● ● ●			
32×32	5,000			● ● ● ●	● ● ● ● ● ●	● ● ● ● ● ●	● ● ● ●		
	6,000				● ● ● ●	● ● ● ●			
35×35	5,000			● ● ● ●	● ● ● ● ● ●	● ● ● ● ● ●	● ● ● ●		
38.5×38.5	〃			● ● ● ●	● ● ● ● ● ●	● ● ● ● ● ●	● ● ● ●		
40×40	5,000				● ● ● ●	● ● ● ● ● ●	● ● ● ● ● ●	● ● ● ●	
	6,000				● ● ● ●	● ● ● ●			
41×41	5,000			● ● ● ●	● ● ● ● ● ●	● ● ● ● ● ●	● ● ● ●		
	6,000				● ● ● ●	● ● ● ●			
46×46	5,000				● ● ● ● ● ●	● ● ● ● ● ●	● ● ● ●		
50×50	5,000				● ● ● ● ● ●	● ● ● ● ● ●	● ● ● ● ● ●	● ● ● ●	
	6,000				● ● ● ●	● ● ● ●	● ● ● ●	● ● ● ●	
60×60	5,000				● ● ● ● ● ●	● ● ● ● ● ●	● ● ● ● ● ●	● ● ● ●	
	6,000				● ● ● ●	● ● ● ●	● ● ● ●	● ● ● ●	
75×75	5,000				● ● ● ● ● ●	● ● ● ● ● ●	● ● ● ● ● ●	● ● ● ●	
	6,000				● ● ● ●	● ● ● ●	● ● ● ●	● ● ● ●	
100×100	5,000				● ● ● ● ● ●	● ● ● ● ● ●	● ● ● ● ● ●	● ● ● ●	
	6,000				● ● ● ●	● ● ● ●	● ● ● ●	● ● ● ●	

● = HL ● = #400 ● = #800 ● = 未研磨

角パイプ 長方形 SUS304 ■単位:mm

サイズ	厚さ		SUS304				
	長さ		1.0	1.2	1.5	2.0	3.0
19×10	4,000		● ●	● ● ● ●			
22×12	5,000		● ●	● ● ● ●	● ● ● ●		
25×12	〃			● ● ● ●	● ● ● ●	● ● ● ●	
24×14	〃		● ●	● ● ● ●	● ● ● ●	● ● ● ●	
32×16	5,000		● ●	● ● ● ●	● ● ● ●	● ● ● ●	
	6,000				● ● ● ●	● ● ● ●	
30×20	5,000			● ● ● ●	● ● ● ●	● ● ● ●	
	6,000				● ● ● ●	● ● ● ●	
30×25	5,000			● ● ● ●	● ● ● ●	● ● ● ●	
40×18	〃		● ● ● ●	● ● ● ●	● ● ● ●	● ● ● ●	
40×20	5,000			● ● ● ●	● ● ● ●	● ● ● ●	● ● ● ●
	6,000				● ● ● ●	● ● ● ●	
40×25	5,000			● ● ● ●	● ● ● ●	● ● ● ●	● ● ● ●
	6,000				● ● ● ●	● ● ● ●	
50×20	5,000			● ● ● ●	● ● ● ●	● ● ● ●	● ● ● ●
	6,000				● ● ● ●	● ● ● ●	
50×25	5,000				● ● ● ●	● ● ● ●	● ● ● ●
	6,000				● ● ● ●	● ● ● ●	
51×26	5,000			● ● ● ●	● ● ● ●	● ● ● ●	● ● ● ●
50×30	5,000				● ● ● ●	● ● ● ●	● ● ● ●
	6,000				● ● ● ●	● ● ● ●	
60×25	5,000				● ● ● ●	● ● ● ●	● ● ● ●
60×30	5,000				● ● ● ●	● ● ● ●	● ● ● ●
	6,000				● ● ● ●	● ● ● ●	● ● ● ●
61×32	5,000				● ● ● ●	● ● ● ●	● ● ● ●
	6,000				● ● ● ●	● ● ● ●	
70×25	5,000				● ● ● ●	● ● ● ●	
60×40	〃				● ● ● ●	● ● ● ●	● ● ● ●
65×18	〃			● ● ● ●	● ● ● ●	● ● ● ●	
70×30	〃				● ● ● ●	● ● ● ●	● ● ● ●
75×45	5,000				● ● ● ●	● ● ● ●	● ● ● ●
	6,000				● ● ● ●	● ● ● ●	● ● ● ●
80×40	5,000				● ● ● ●	● ● ● ●	● ● ● ●
	6,000				● ● ● ●	● ● ● ●	● ● ● ●
90×30	5,000				● ● ● ●	● ● ● ●	● ● ● ●
90×50	〃				● ● ● ●	● ● ● ●	● ● ● ●
100×40	〃				● ● ● ●	● ● ● ●	● ● ● ●
100×50	5,000				● ● ● ●	● ● ● ●	● ● ● ●
	6,000				● ● ● ●	● ● ● ●	● ● ● ●
120×60	5,000				● ● ● ●	● ● ● ●	● ● ● ●
125×75	〃				● ● ● ●	● ● ● ●	● ● ● ●
150×50	〃				● ● ● ●	● ● ● ●	● ● ● ●

- 荷台用部品
- 荷台用補助部品
- フエンダー・工具箱・タンク・タイヤ・カバー
- バン・ウイング部材 (アルミ・オリ材含む)
- バン・ウイング部品
- 荷役部品
- ランプ・電装部品
- 保安部品
- 補修部品
- ダンプ部品
- 導風板
- 素材

ステンレス チャンネル

チャンネル SUS304・316・316L(熱間圧延品)

※メーカー在庫品は変更になる場合があります。都度お問い合わせください。

サイズ 厚さ×辺×高さ t × B × H	長さ mm	断面積 cm ²	Kg/P		重心の位置 cm		断面二次 モーメントcm ⁴		断面二次半径 cm		断面係数 cm ³		研磨
			SUS304	SUS316 SUS316L	Cx	Cy	Ix	Iy	ix	iy	Zx	Zy	
3 × 20 × 40	6,000	2.271	10.8		0	0.59	5.22	0.778	1.52	0.585	2.61	0.553	● 酸洗
3 × 25 × 50	6,000	2.871	13.7		0	0.72	10.6	1.6	1.92	0.746	4.26	0.895	● 酸洗
4 × 50 × 100	4,000	7.823	24.8	24.9	0	1.36	121.0	18.1	3.93	1.52	24.2	4.99	● 酸洗
	6,000	7.823	37.2	37.4	0	1.36	121.0	18.1	3.93	1.52	24.2	4.99	● 酸洗
5 × 40 × 80	4,000	7.548	23.9	24.1	0	1.16	71.1	10.9	3.07	1.20	17.8	3.83	● 酸洗
	6,000	7.548	35.9	36.1	0	1.16	71.1	10.9	3.07	1.20	17.8	3.83	● 酸洗
5 × 50 × 100	4,000	9.643	30.6	20.8	0	1.40	146.0	22.1	3.89	1.52	29.2	6.16	● 酸洗
	6,000	9.643	45.9	46.2	0	1.40	146.0	22.1	3.89	1.52	29.2	6.16	● 酸洗
6 × 50 × 100	4,000	11.37	36.0	36.3	0	1.43	168.0	25.3	3.85	1.49	33.7	7.09	● 酸洗
	6,000	11.37	54.1	54.4	0	1.43	168.0	25.3	3.85	1.49	33.7	7.09	● 酸洗
○ 6 × 60 × 120	6,000	13.79	65.4		0	1.69	300.0	45.6	4.66	1.82	50.0	10.6	● 酸洗
6 × 65 × 130	4,000	15.12	48.0	48.4	0	1.80	390.0	58.9	5.08	1.97	60.0	12.5	● 酸洗
	6,000	15.12	72.0	72.6	0	1.80	390.0	58.9	5.08	1.97	60.0	12.5	● 酸洗
6 × 75 × 150	4,000	17.52	55.6	56.0	0	2.05	609.0	92.3	5.89	2.30	81.2	16.9	● 酸洗
	6,000	17.52	83.4	84.0	0	2.05	609.0	92.3	5.89	2.30	81.2	16.9	● 酸洗
9 × 75 × 150	4,000	25.54	81.2	81.6	0	2.16	850.0	129.0	5.77	2.25	113.0	24.2	● 酸洗
	6,000	25.54	122.0	122.0	0	2.16	850.0	129.0	5.77	2.25	113.0	24.2	● 酸洗
○ 10 × 100 × 200	4,000	38.22	121.2	122.0	0	2.81	2310.0	351.0	7.77	3.03	231.0	48.8	● 酸洗
	6,000	38.22	182.0	183.0	0	2.81	2310.0	351.0	7.77	3.03	231.0	48.8	● 酸洗

○は溶接チャンネル

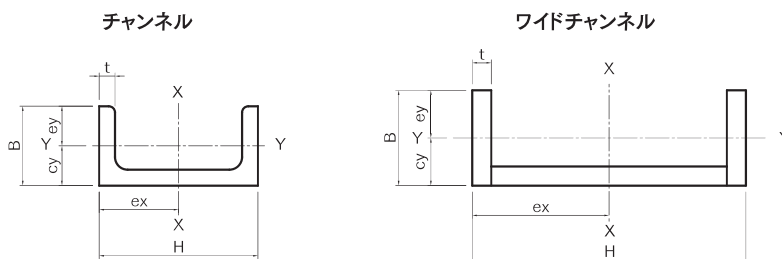

ワイドチャンネル SUS304(溶接品)

※メーカー在庫品は変更になる場合があります。都度お問い合わせください。

サイズ 厚さ×辺×高さ t × B × H	長さ mm	断面積 cm ²	Kg/P SUS304	重心の位置 cm		断面二次 モーメントcm ⁴		断面二次半径 cm		断面係数 cm ³		研磨
				Cx	Cy	Ix	Iy	ix	iy	Zx	Zy	
			6 × 65 × 220	6,000	20.52	97.8	0	1.41	1370	68.0	8.16	
6 × 65 × 230	6,000	21.12	100	0	1.37	1520	68.8	8.49	1.80	133	13.4	● 酸洗
6 × 75 × 250	6,000	23.60	112	0	1.59	2050	105	9.34	2.11	165	17.8	● 酸洗
9 × 75 × 250	6,000	34.65	165	0	1.71	2930	149	9.20	2.08	235	25.8	● 酸洗
9 × 90 × 250	6,000	37.35	178	0	2.18	3320	254	9.43	2.61	266	37.2	● 酸洗
9 × 90 × 300	6,000	41.85	199	0	1.99	5160	266	11.10	2.52	344	38.0	● 酸洗
9 × 100 × 300	6,000	43.63	206	0	2.36	5542	369	11.27	2.91	369	48.3	● 酸洗
10 × 100 × 250	6,000	43.25	206	0	2.61	3928	385	9.53	2.98	314	52.1	● 酸洗
10 × 90 × 300	6,000	46.22	220	0	2.02	5650	290	11.10	2.50	377	41.5	● 酸洗
10 × 100 × 300	6,000	48.22	229	0	2.33	6080	394	11.20	2.86	405	51.4	● 酸洗

※ワイドチャンネルは全て溶接品

荷台用部品

荷台用補助部品

フエンター・工具箱・タンク・クレーン・ワイヤ

バンディング部材(アルミ・スチール)

バンディング部品

荷役部品

ランプ・電装部品

保安部品

補修部品

ダンプ部品

導風板

素材